

# **Why Japan remains skeptical of restructuring**

## **Study of Electricity Market Bidding Characteristics for Modeling Generation Capacity Growth**

**Satoru Ihara**

Retired (urotas@ieee.org)

**Tetsuo Sasaki, Toshihisa Kadoya**

Kansai Electric Power Company, Osaka, Japan

Presented to:

New England Chapter

International Association for Energy Economics

Cambridge, Massachusetts

November 17, 2004

## **Study Objective:**

Critically evaluate American way of deregulating the electricity market.

# Japan – 130 million people, 200 GW system

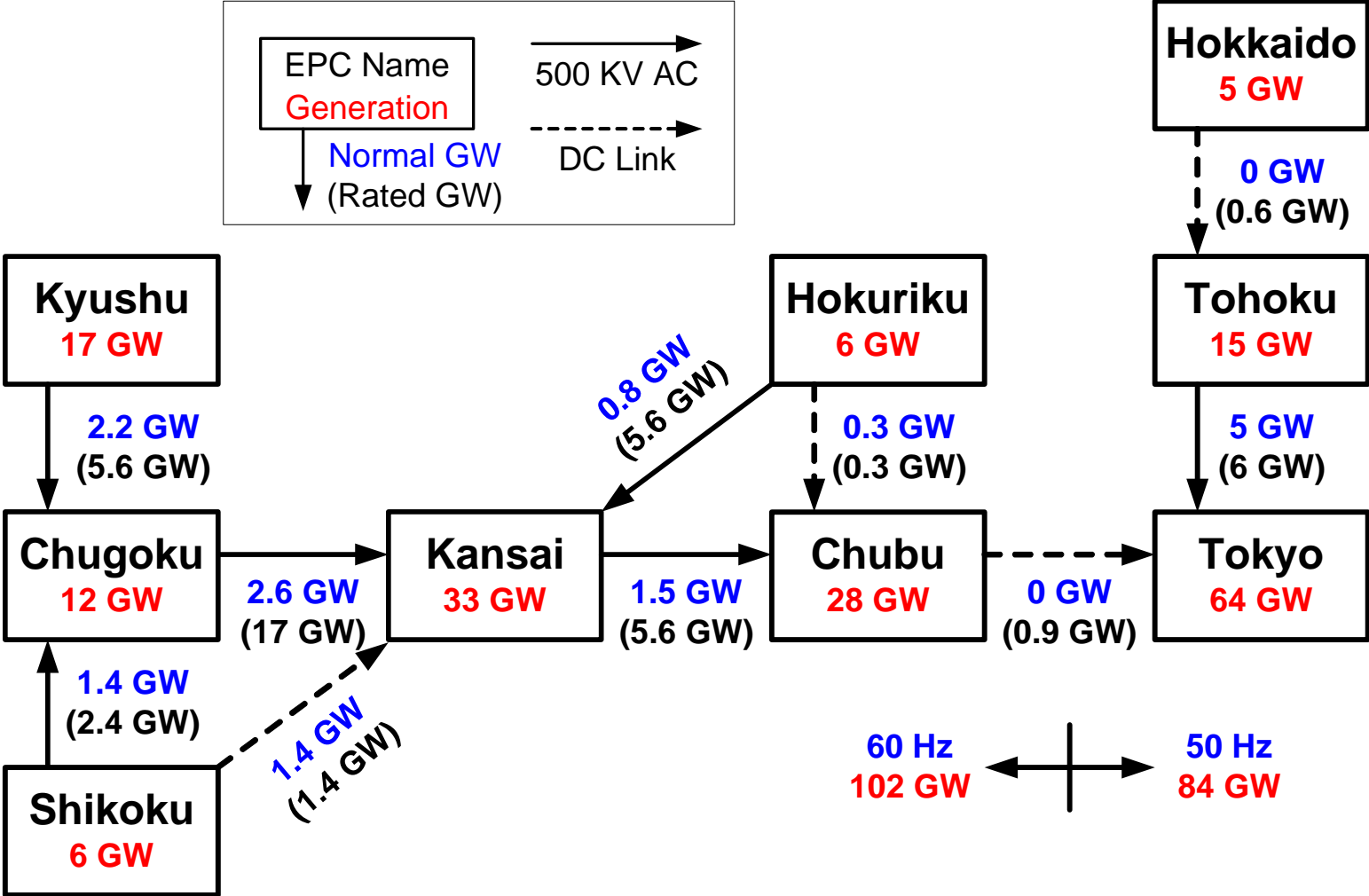

# Japan

- With declining population, GDP and power system will cease to expand.
- Without natural resources, Japan is totally dependent on imported fuel and raw material.
- Cooperation and social benefits are valued more than competition and individual gains.
- Power companies will remain vertically integrated with retail market deregulated.
- Early retirement of inefficient units is reducing total fuel consumption. Generation mix is optimized.
- Transmission losses are minimized through self-sufficient generation within each company while maintaining tie-flow capabilities for emergency use.

# Boom-burst cycles in generation capacity growth ?

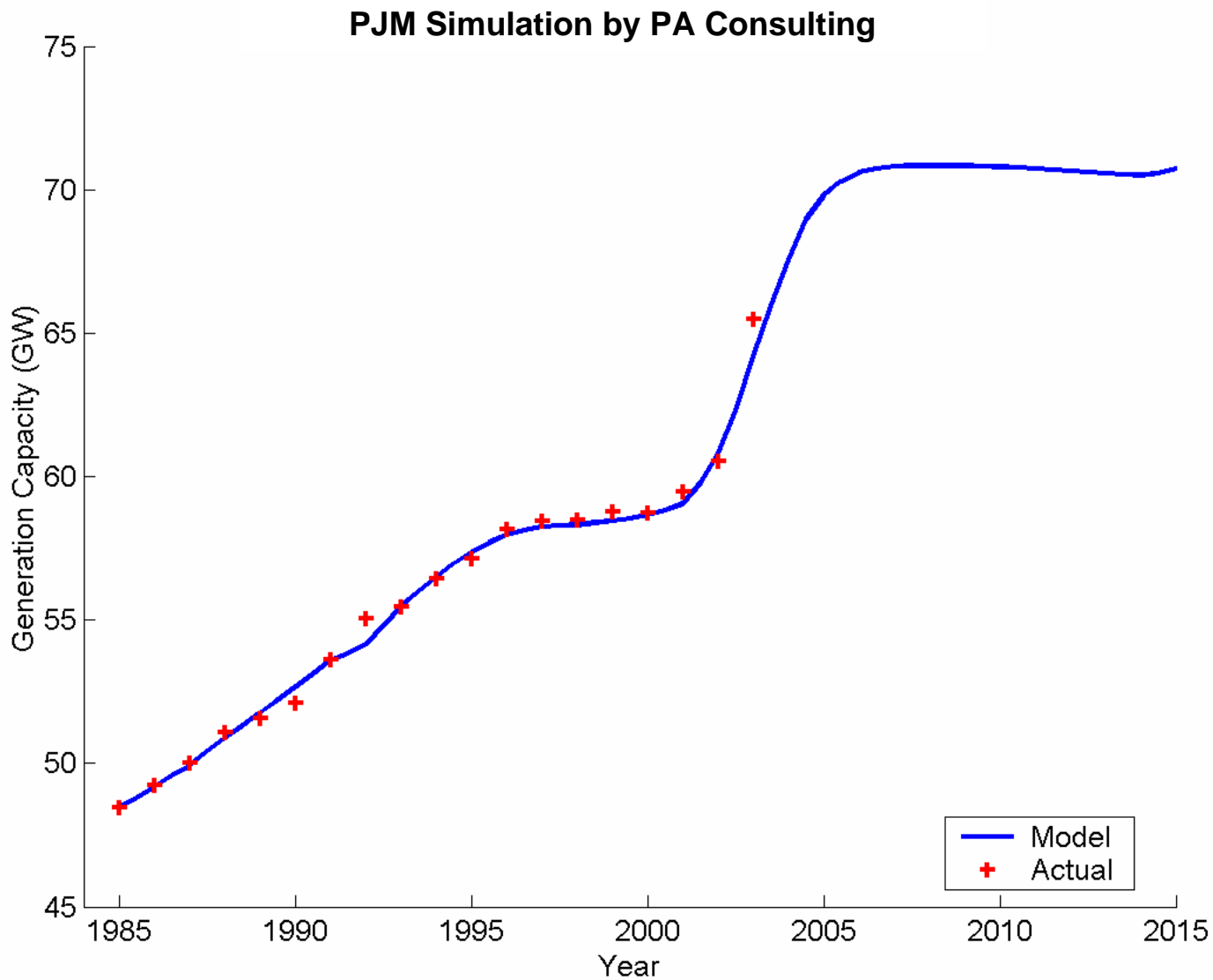

# Where is growth ?

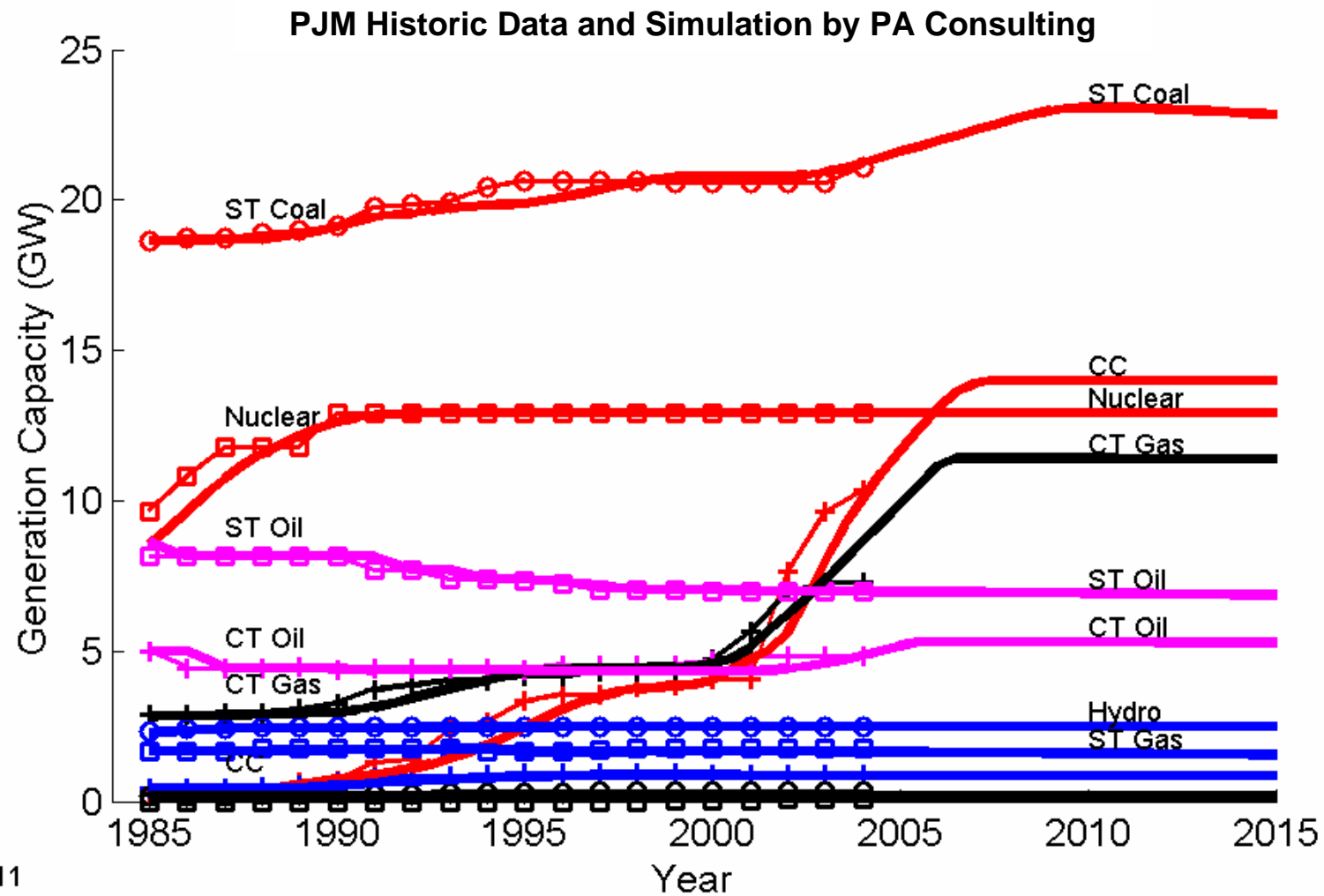

CAP11

# Limitation of Forecasting Model

- The model involves many assumptions, thousands of state variables, many feedback loops and delays. It is almost a black box.
- We need to believe all the assumptions.
- The past influences the future but cannot be extrapolated into the future:
  - When will new nuclear plants be constructed?
  - Will hydro plants like NYPA's be constructed for the benefit of the people?
  - Will new technologies nobody knows yet change the future?

# Tried to model PJM, NY ISO and ISO NE

(Work by GE Power Systems)

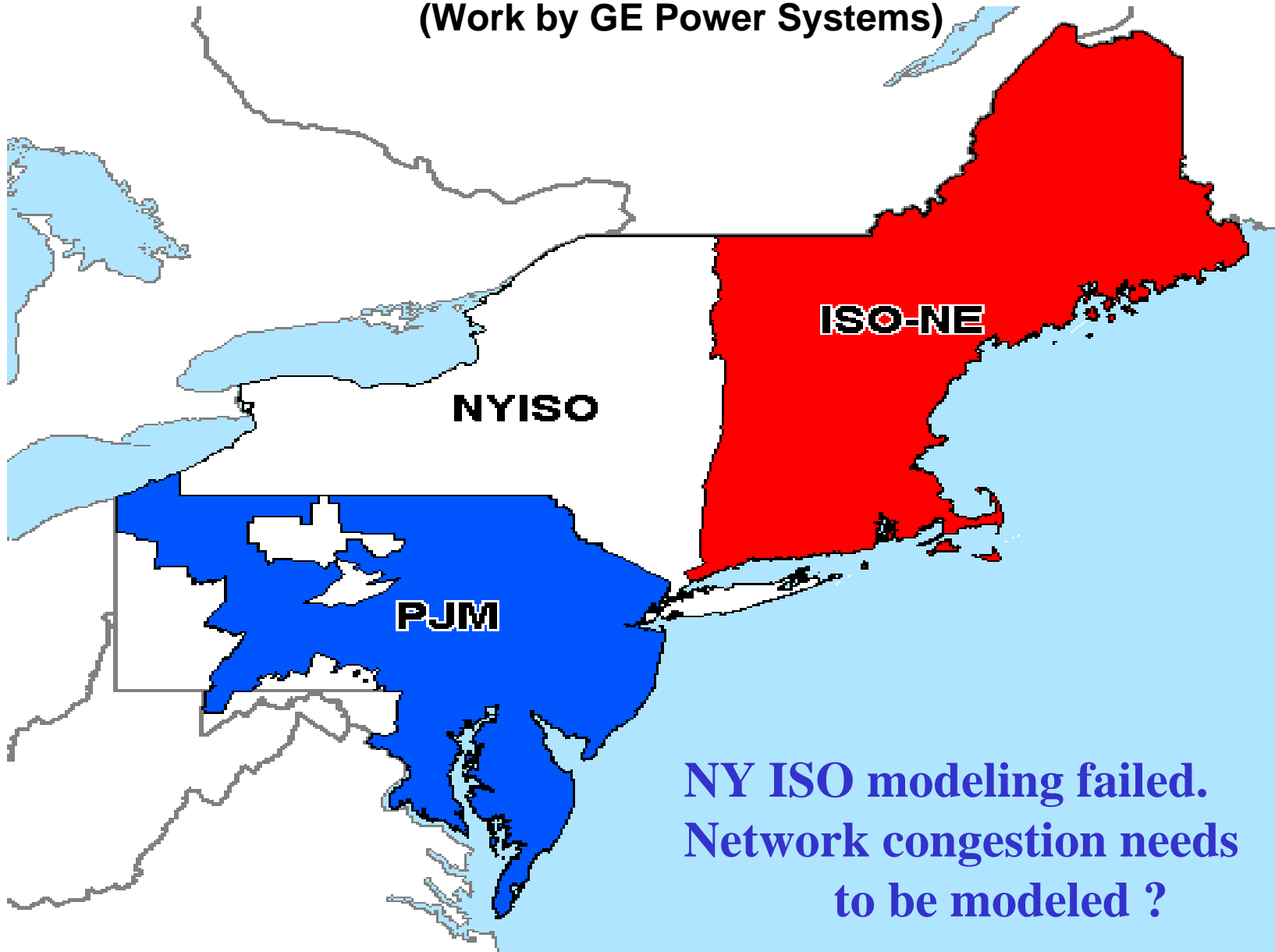

# Modeling Generation Capacity Growth

(Work by GE Power Systems)

**Price Signals**



**New Plant Addition  
Old Plant Retirement**

- Bidder characteristics
- Price formation mechanism

- Developer characteristics
- Plant selection

# Documents on PJM Market Rules as of 2001

(Collected by Andrew P. Hartshorn, LECG, LLC)



# PJM Market Rules – 150 page summary by LECG

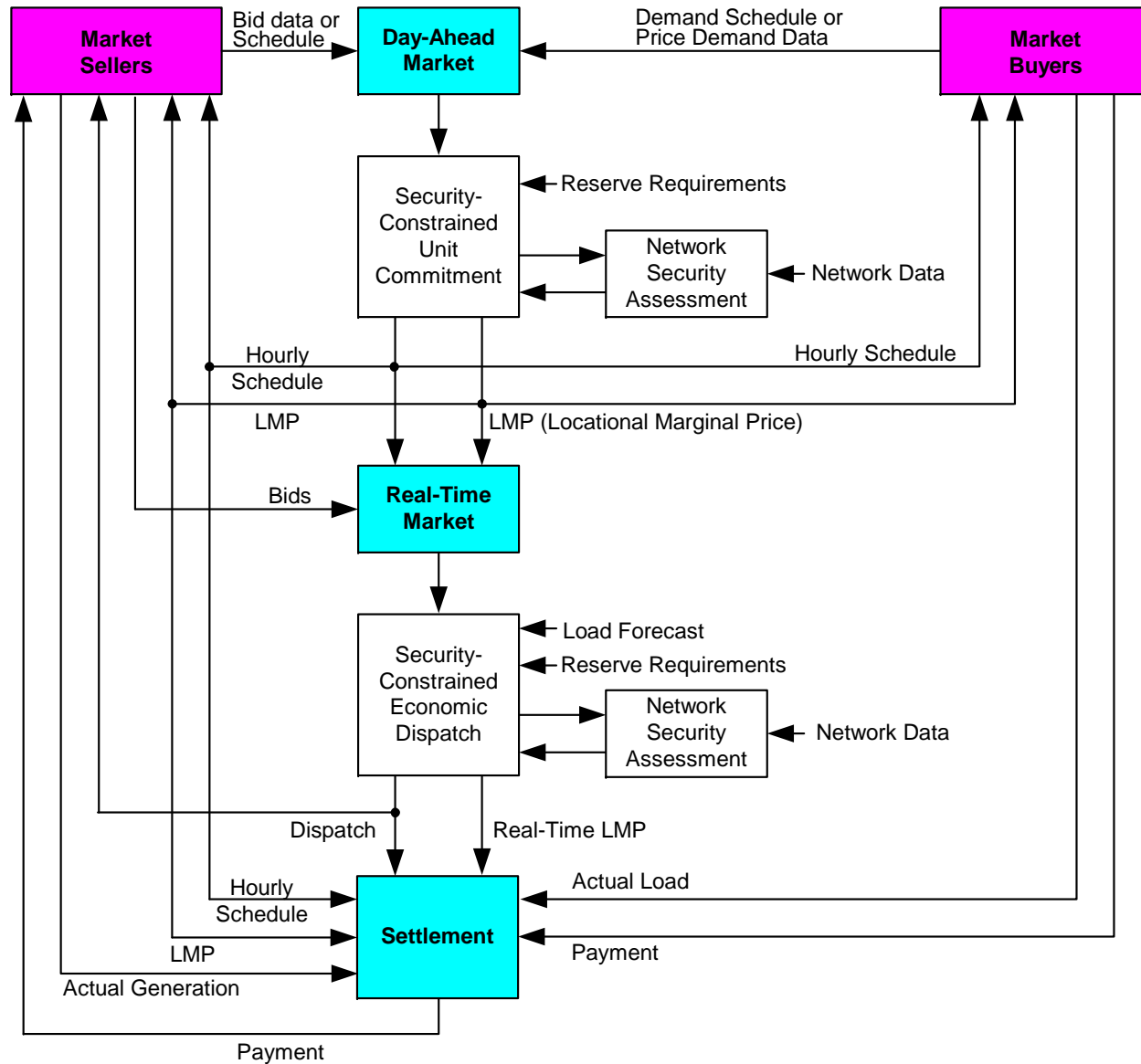

# PJM Electricity Market Data Study by GE Power Systems

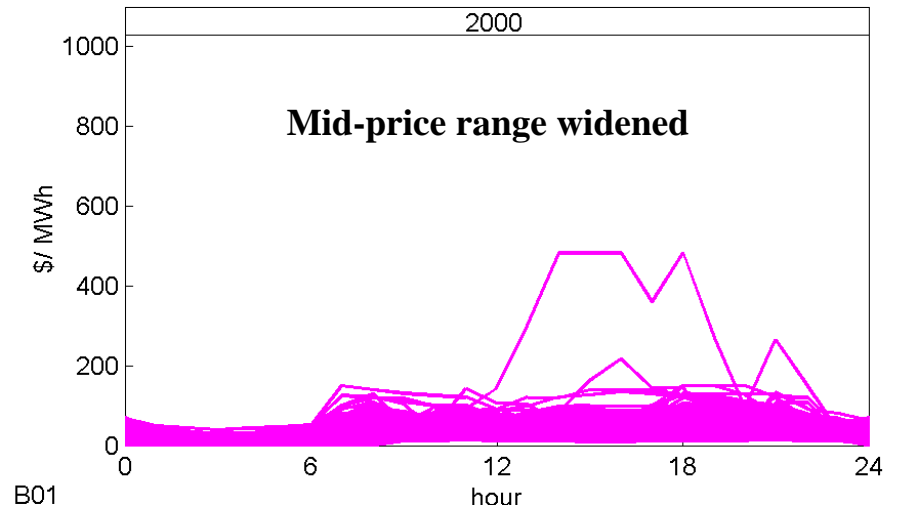
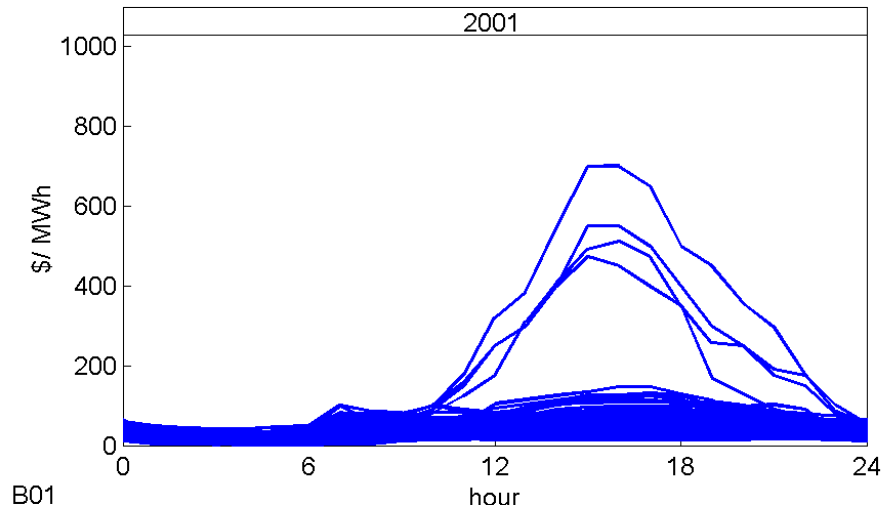
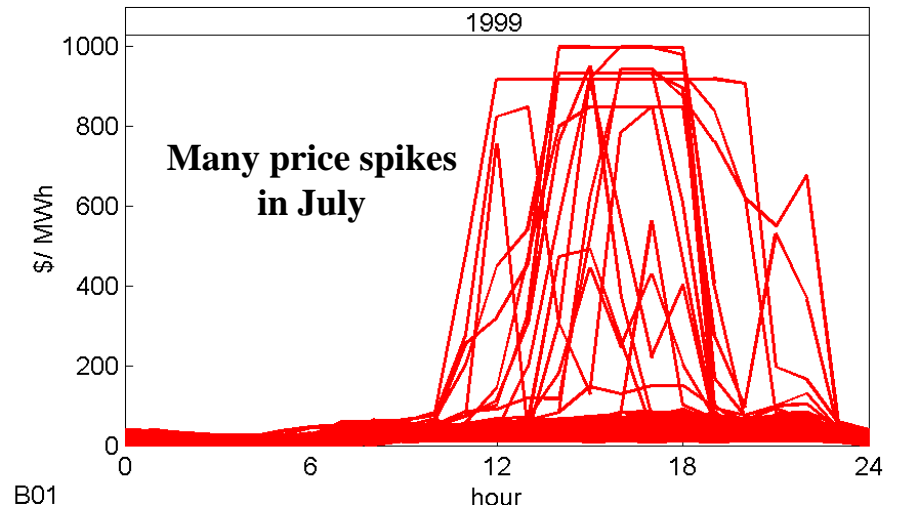
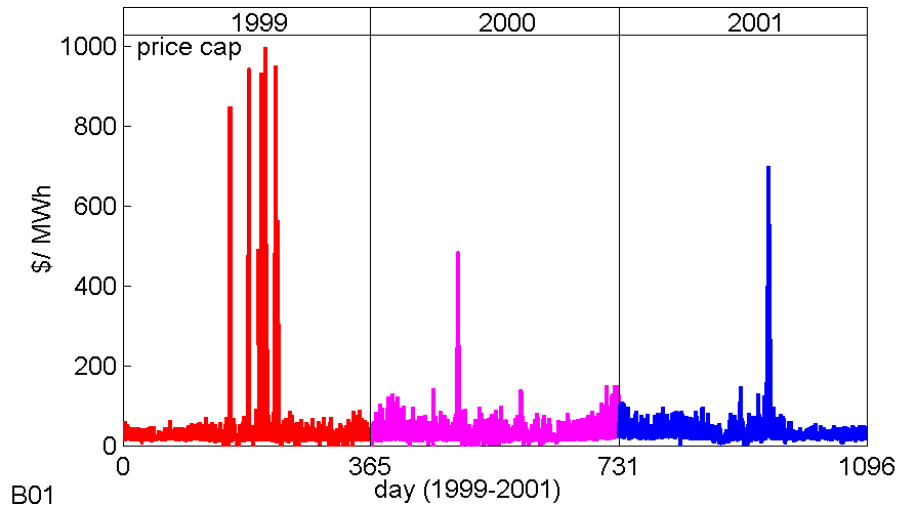

# PJM Electricity Market Data Study by GE Power Systems

1999/07

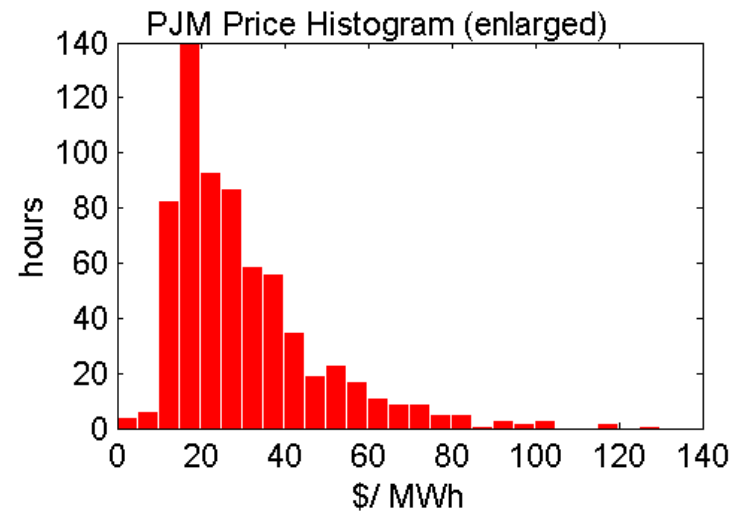
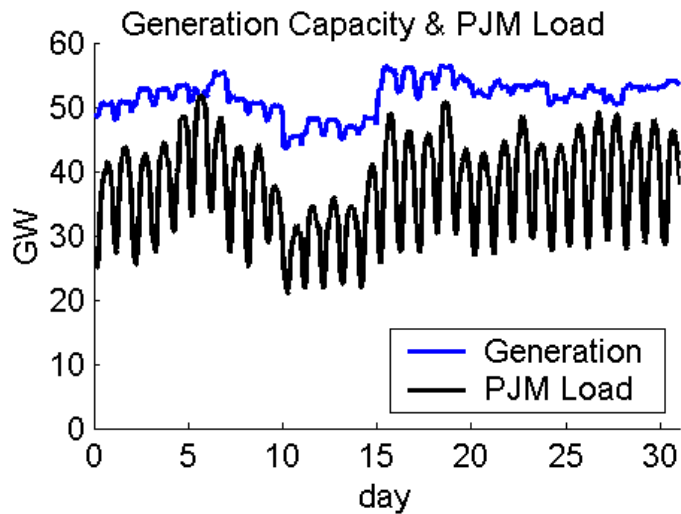
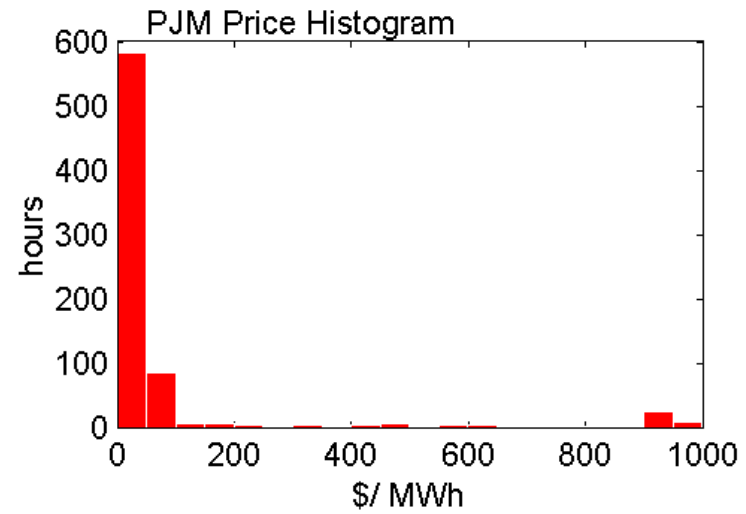
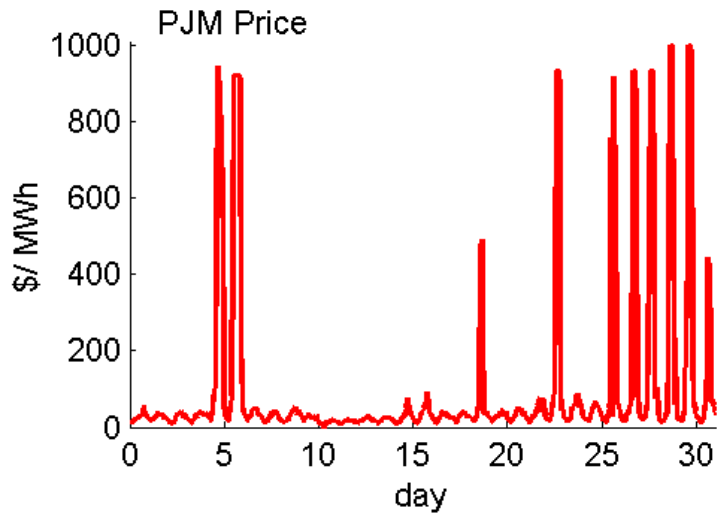

hst2

# Supply Margin Scarcity Resulting in Price Spikes

(PJM Electricity Market Data Study by GE Power Systems)

1999/07

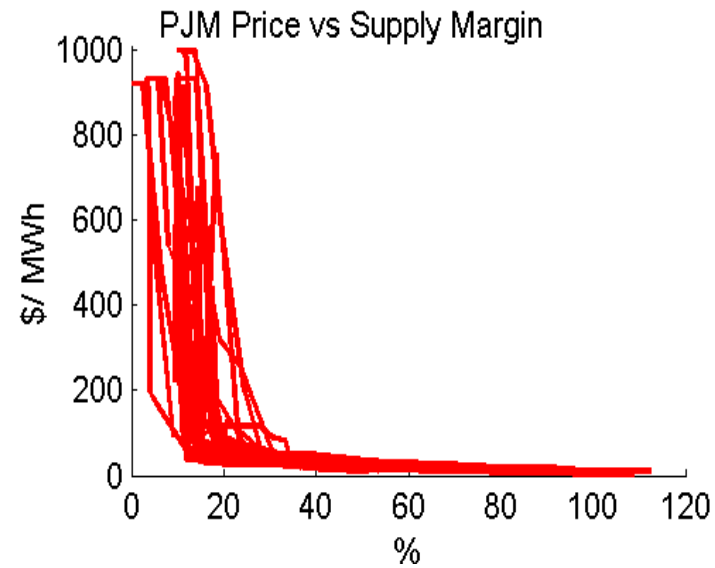
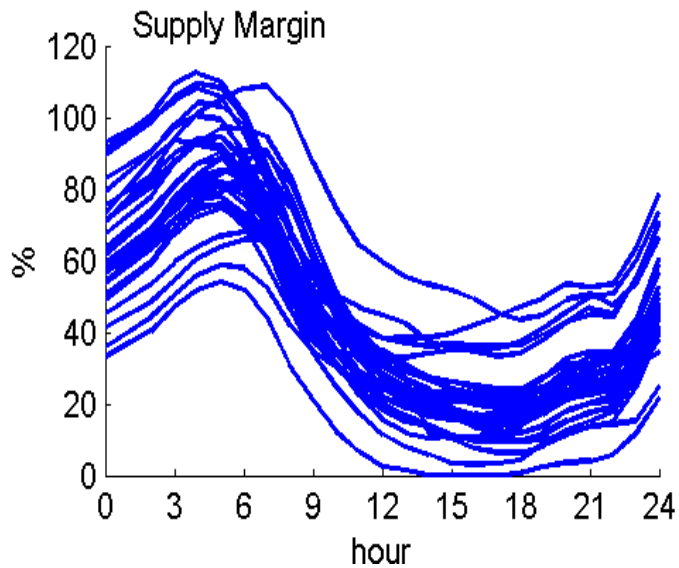
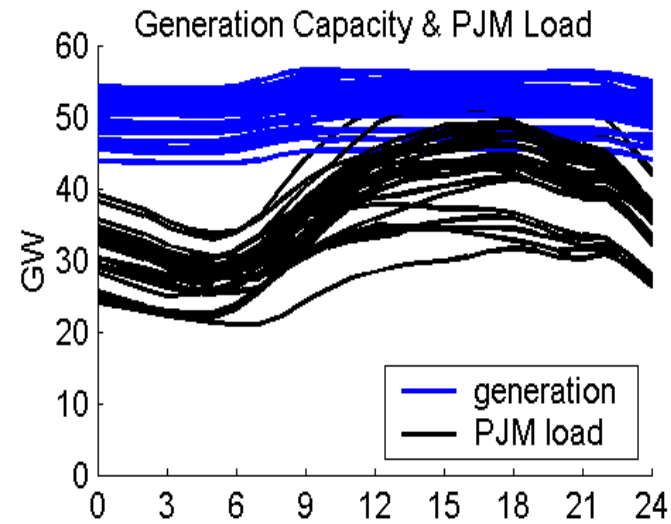
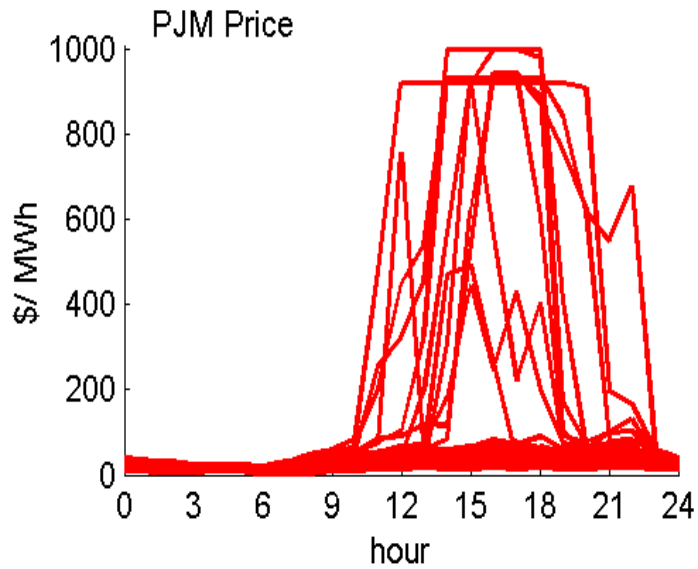

# Large Income during Price Spikes in July 1999.

(PJM Electricity Market Data Study by GE Power Systems)

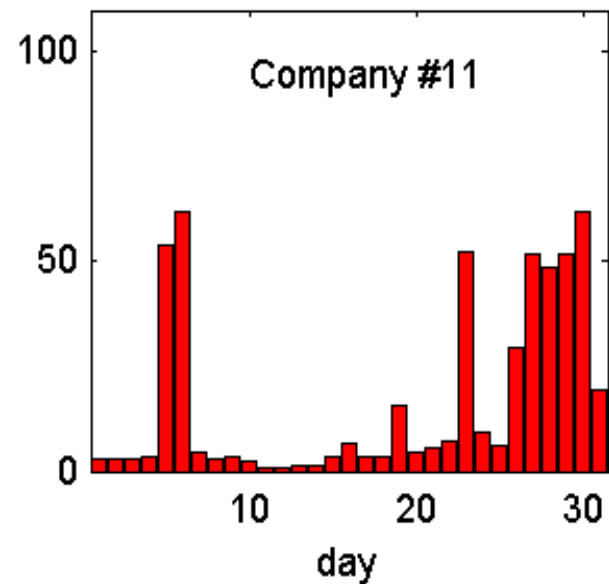
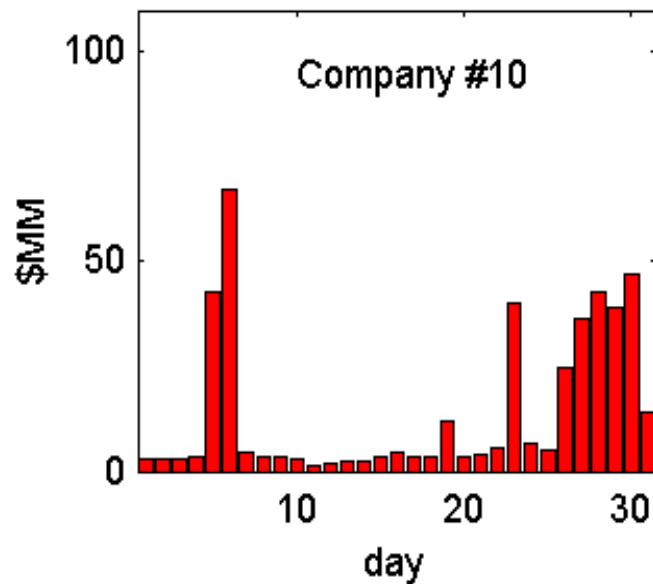
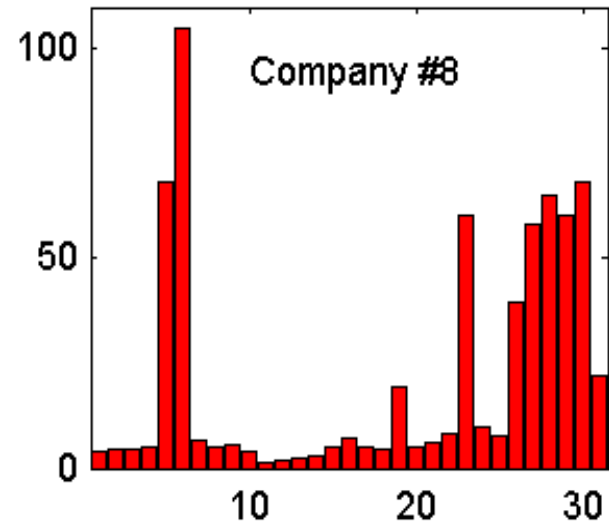
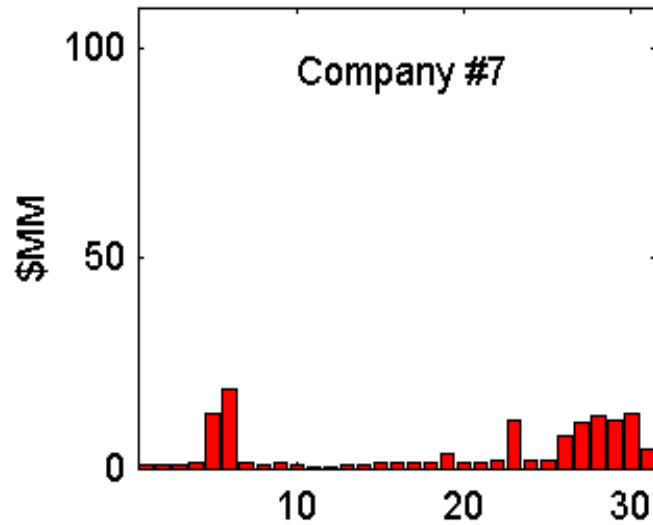

# Three companies might have speculated in July, 1999.

(PJM Electricity Market Data Study by GE Power Systems)

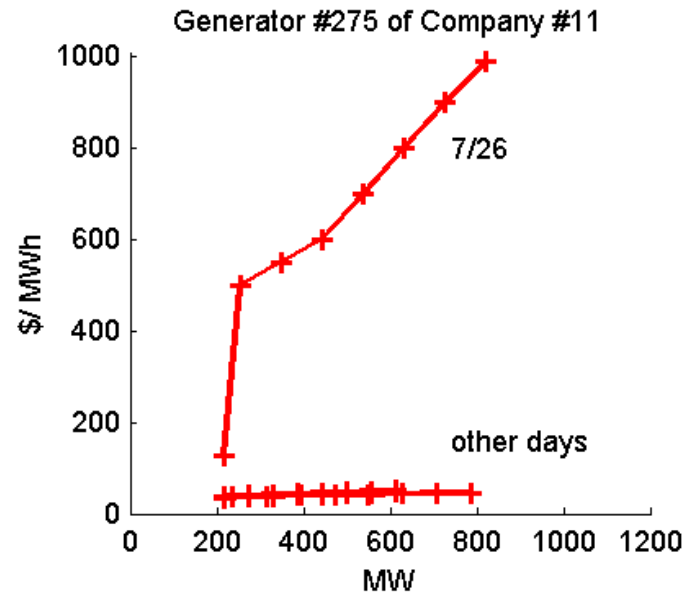
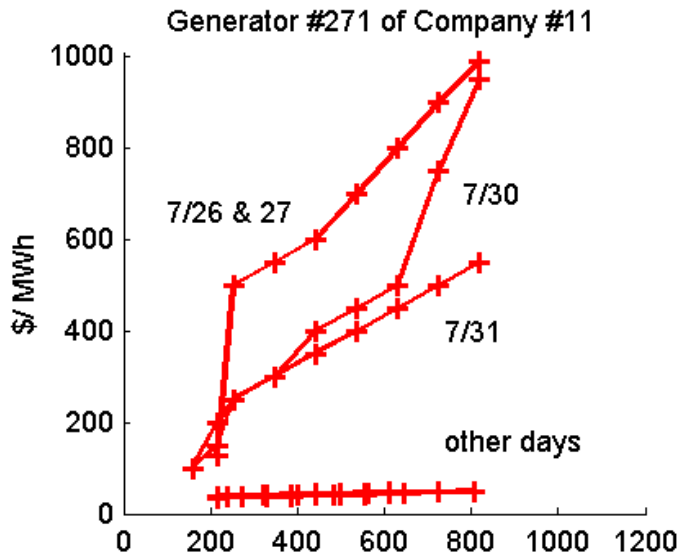
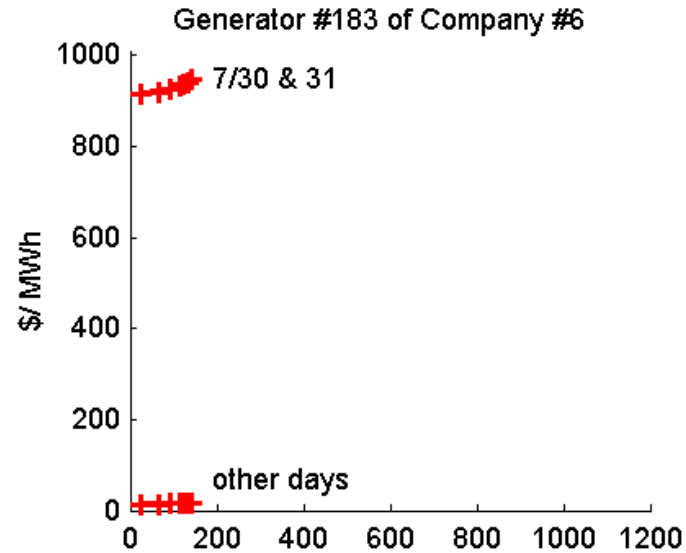
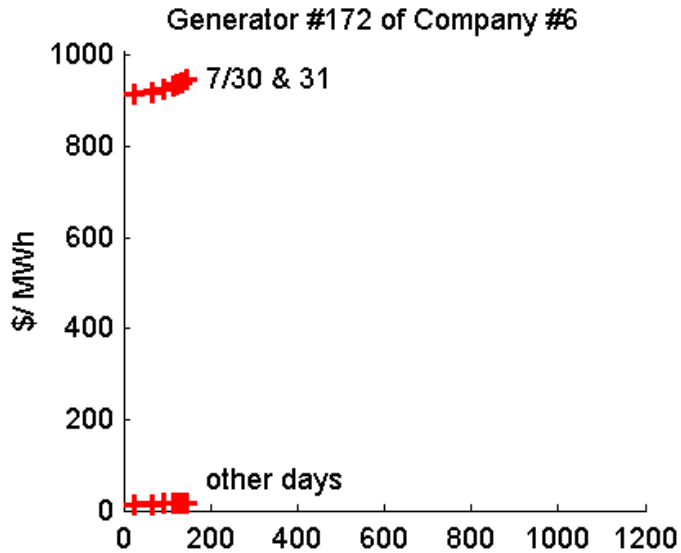

# Who determined the price?

(PJM Electricity Market Data Study by GE Power Systems)

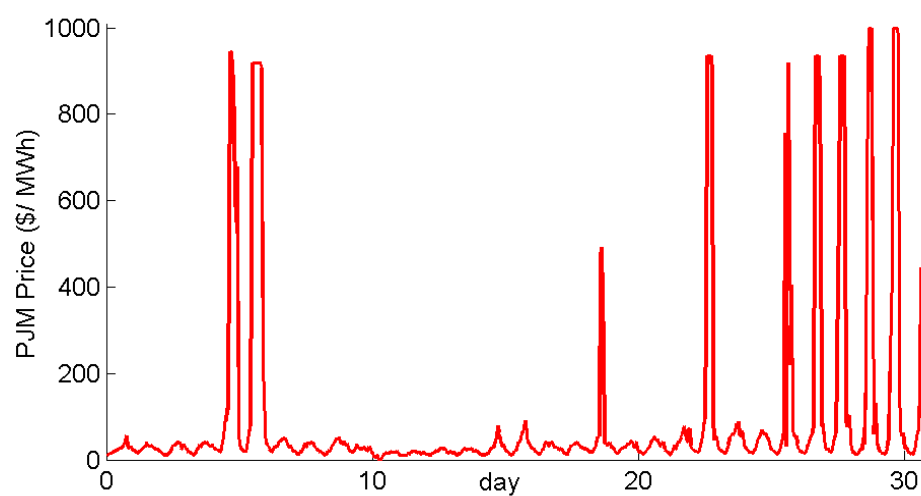
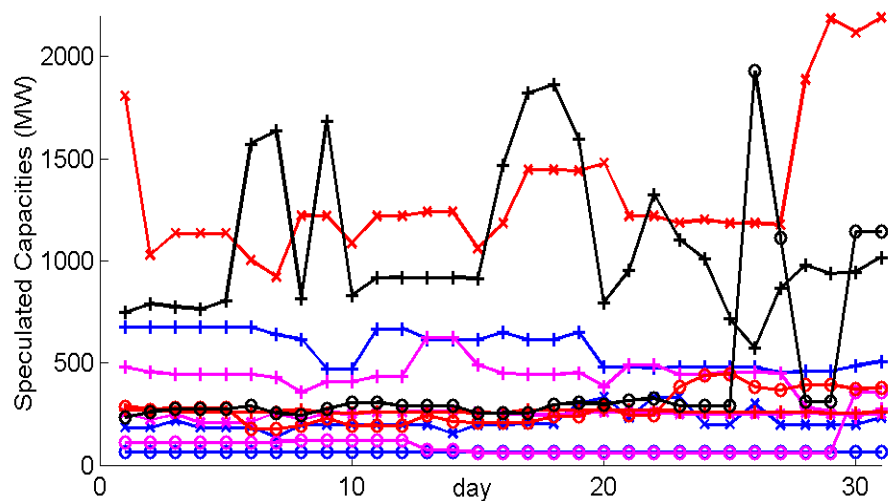
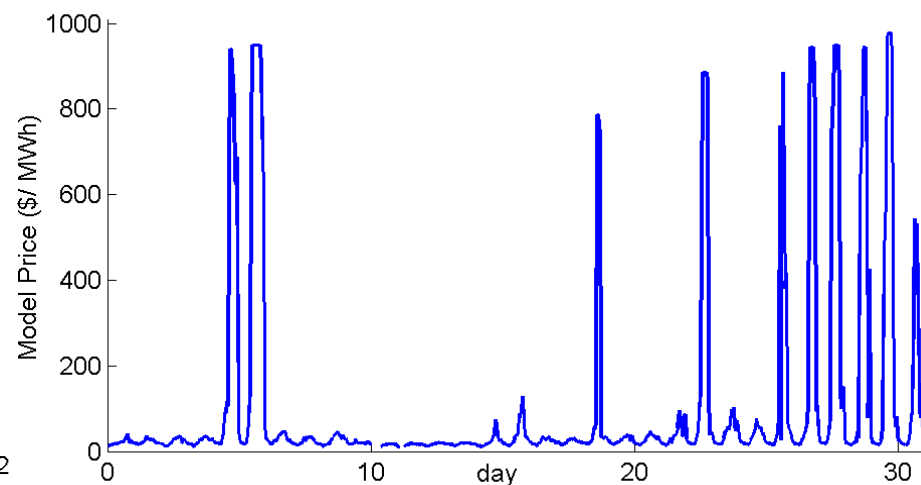
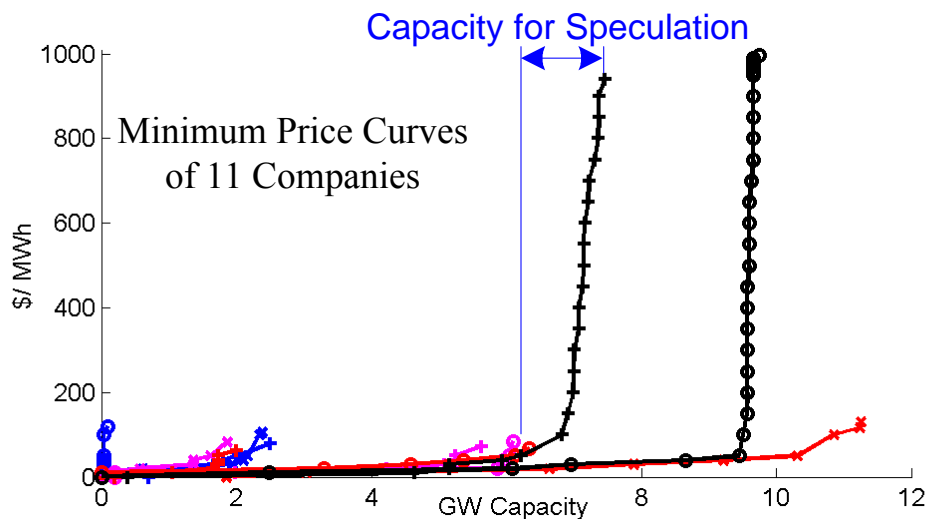

# One company may have determined the price.

(PJM Electricity Market Data Study by GE Power Systems)

Speculated capacities held constant except for one company.

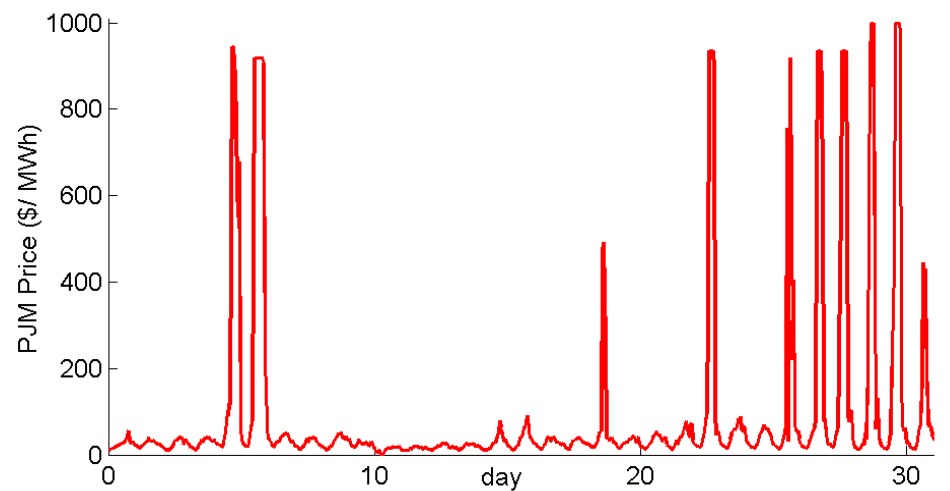
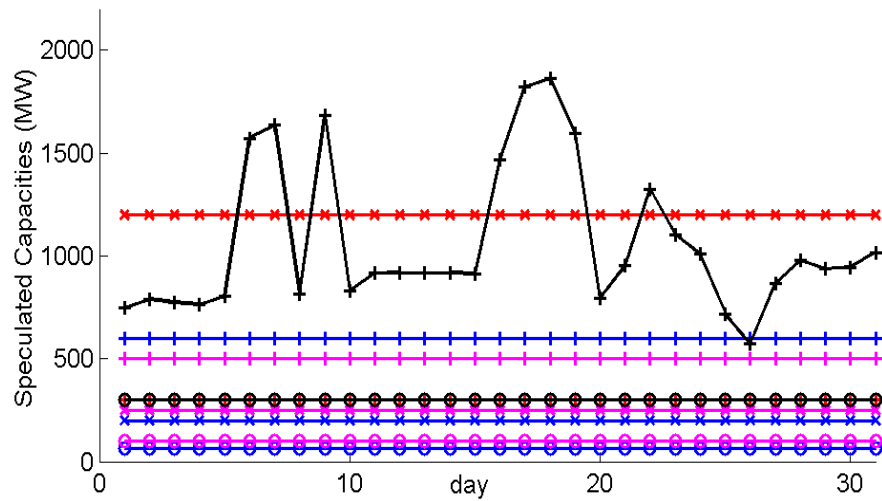
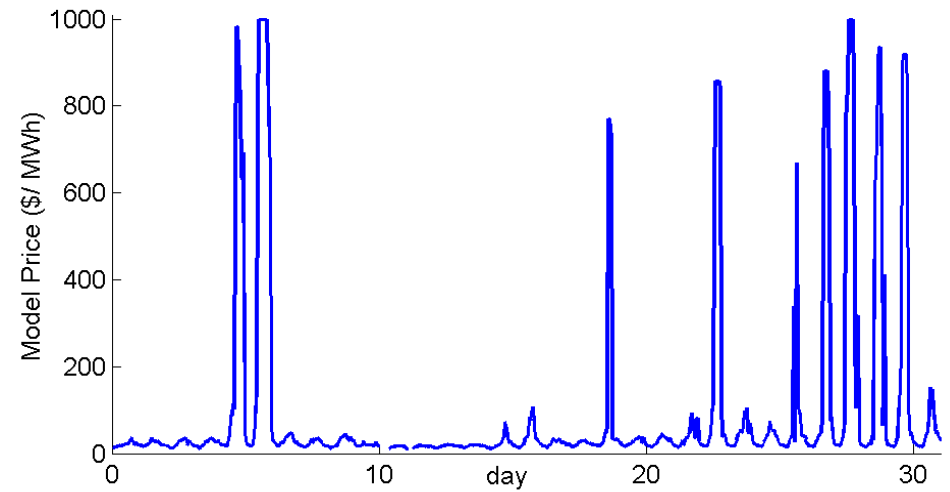

# Observed Speculator Behavior

(PJM Electricity Market Data Study by GE Power Systems)

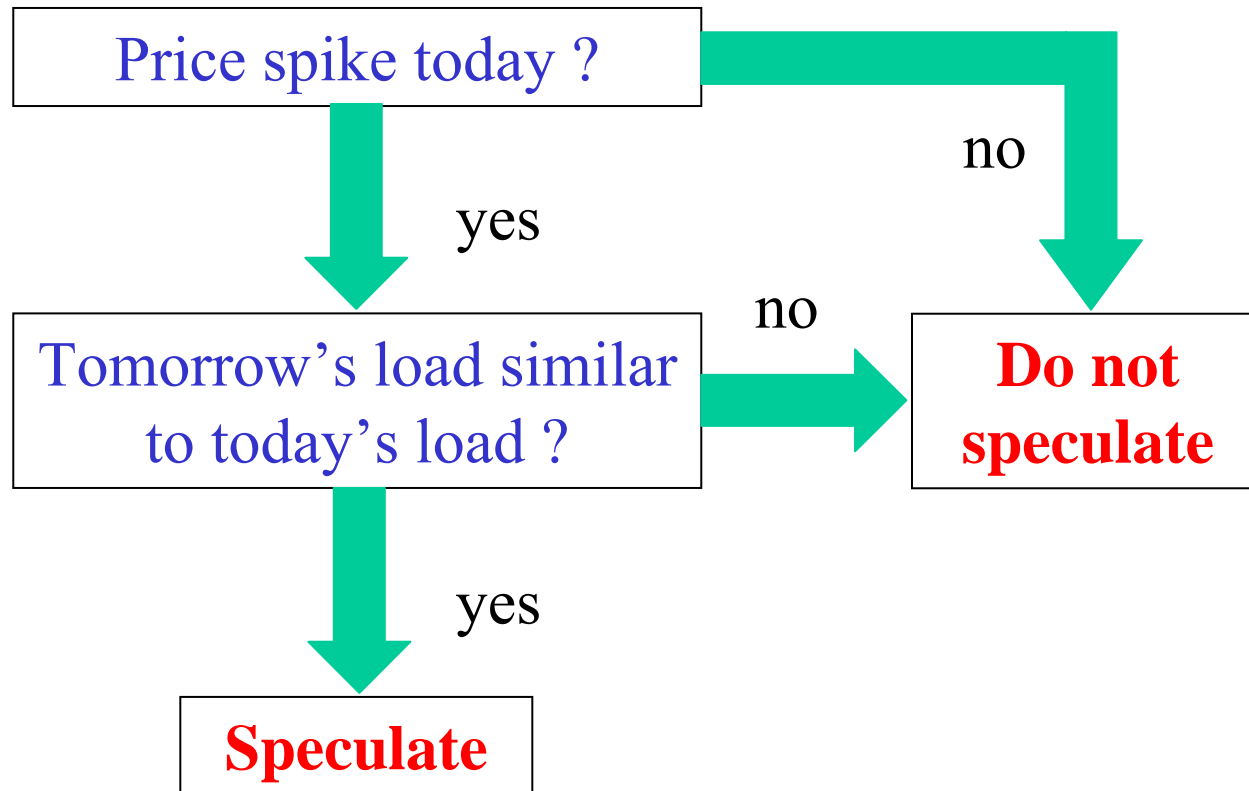

# NY and Neighboring Areas Modeled by GE Power Systems

600 GW System with 6,300 generators, 28,000 buses and 42,000 branches

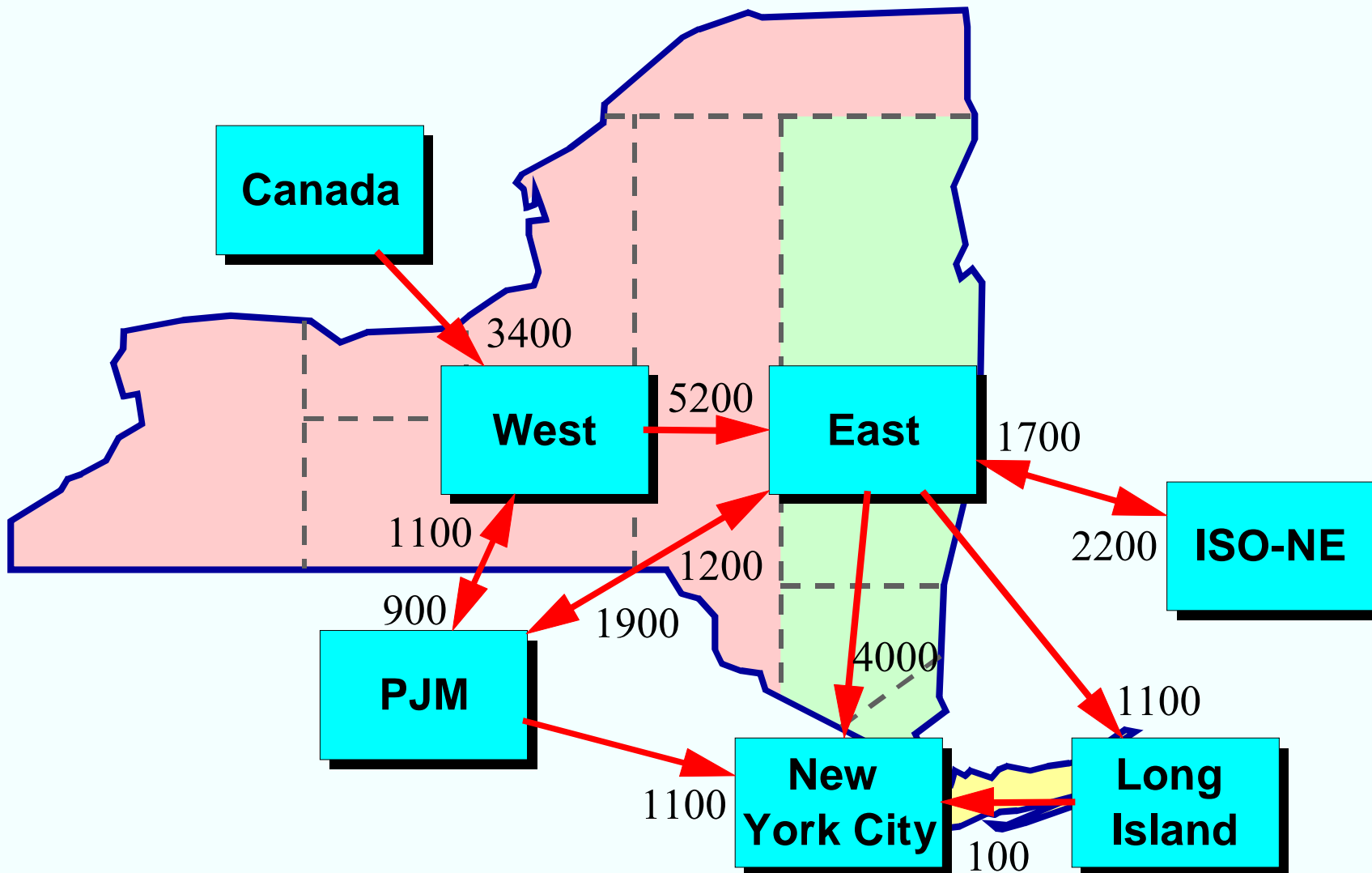

## GE MAPS used for NY ISO Study

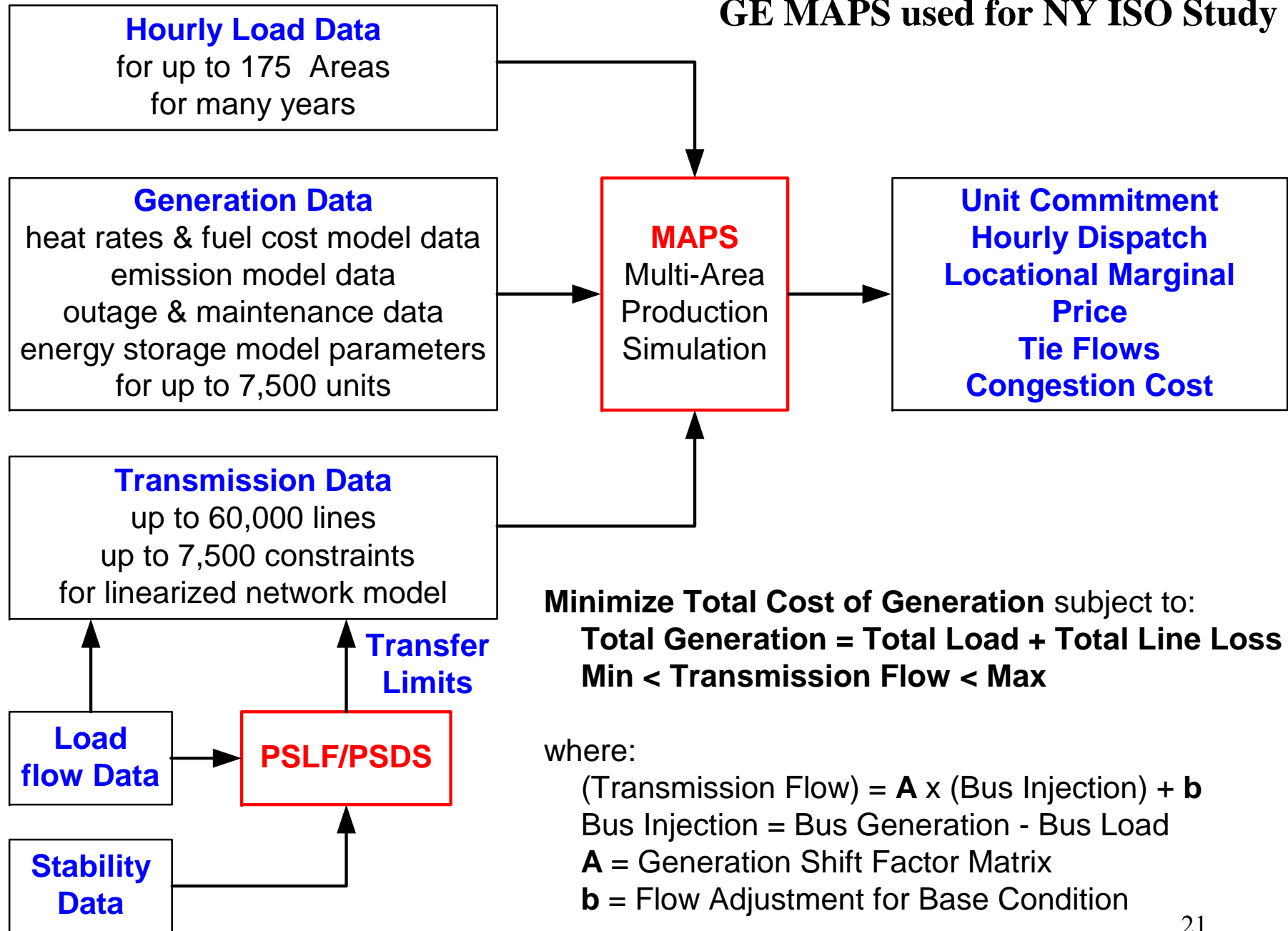

# NY ISO Study under Fictitious Assumptions

(MAPS Simulation by GE Power Systems)

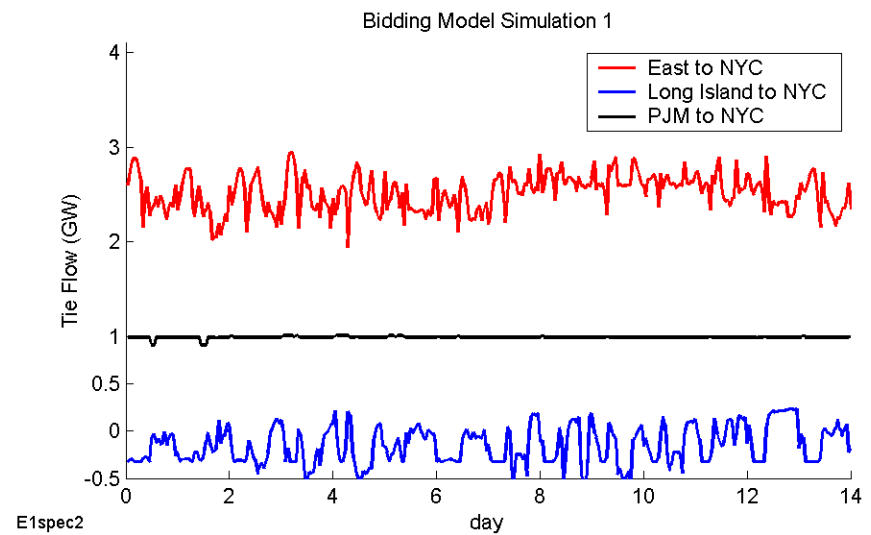
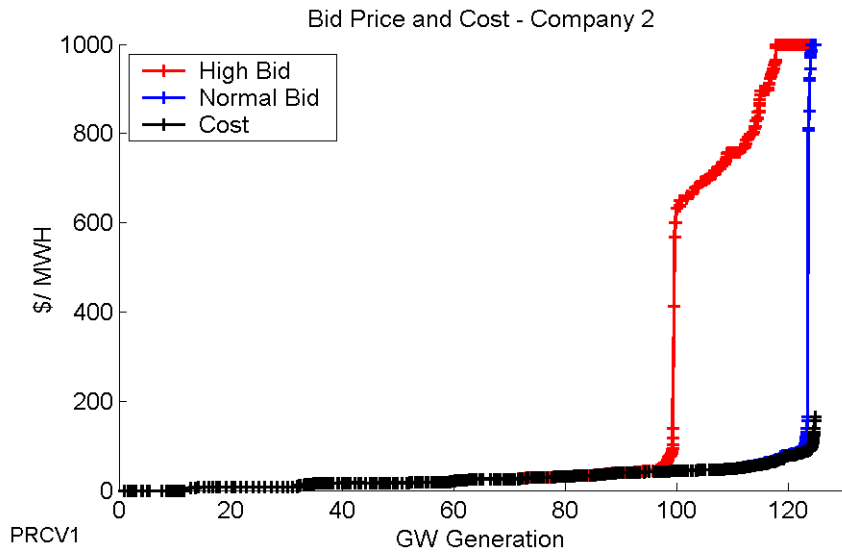
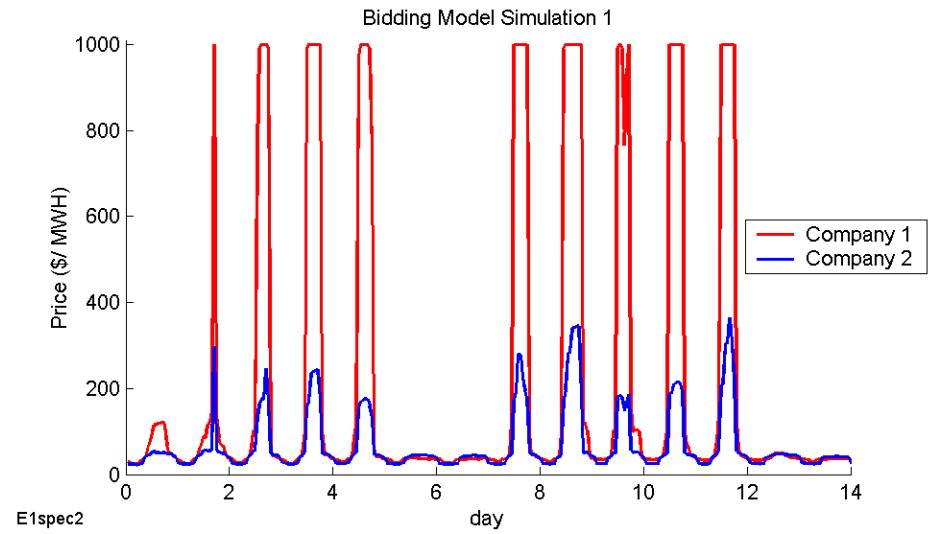
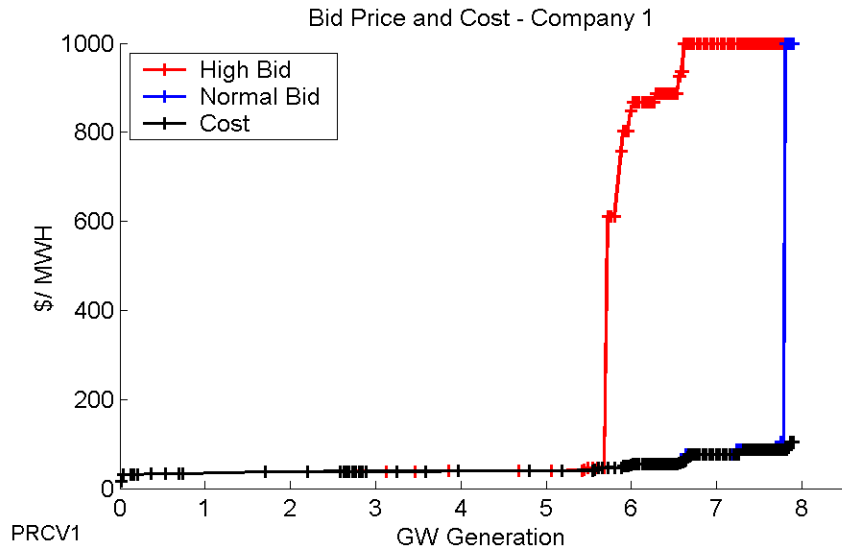

# NY ISO Study

(MAPS Simulation by GE Power Systems)

## Example with fictitious assumptions on:

- Loads and generator availability
- Bidder composition (NYC vs. rest)
- Capacities subject to speculation

## Showed:

- Hard to create initial price spike
- Modeled speculation sustains price spikes
- Prices return to normal as supply margin changes

# Price went quickly up with gas price & slowly down

(PJM Electricity Market Data Study by GE Power Systems)

## Nash Equilibrium ?

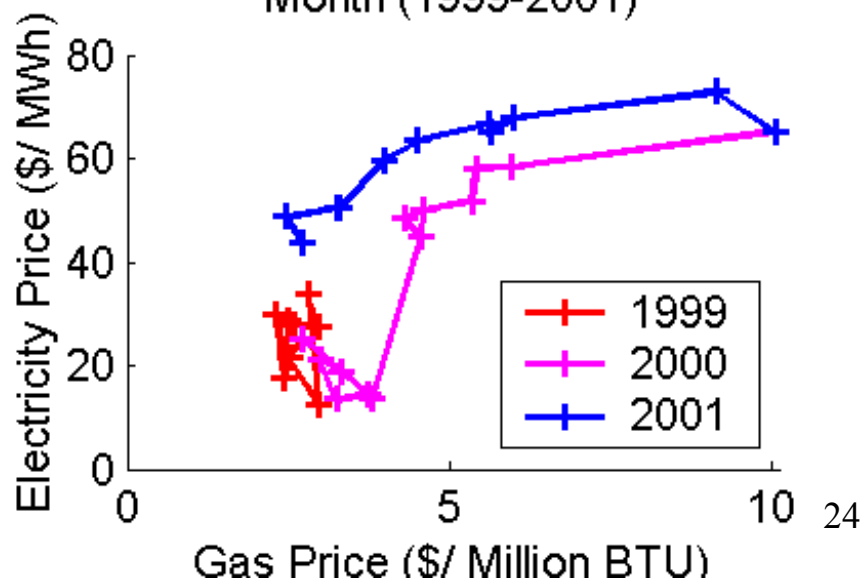
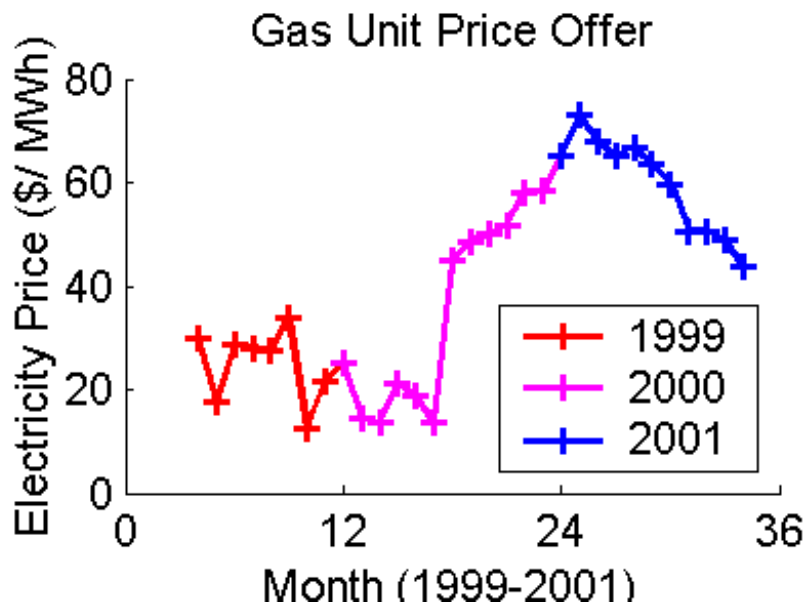
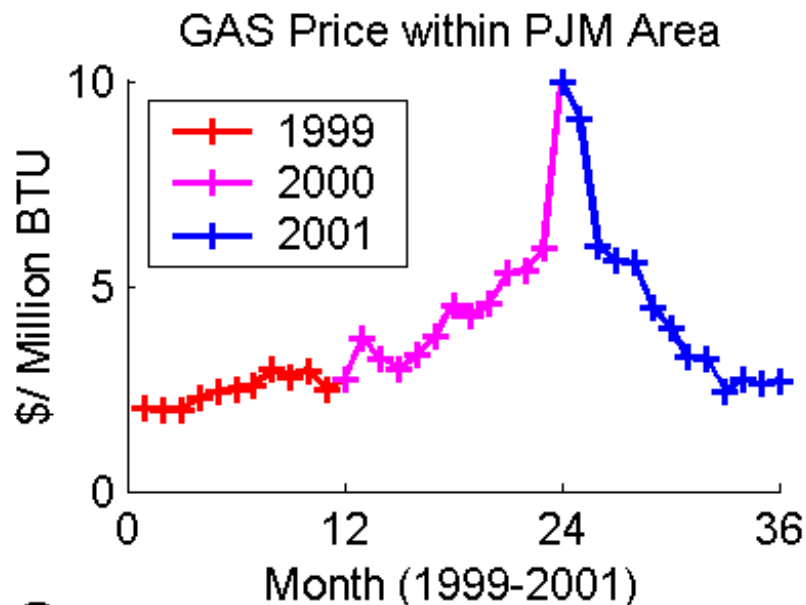

# Simple Example with 2 Players

100 MW capacity each  
 \$60/ MWh cost for both

Load:

100 MW for 12 hours

200 MW for 12 hours

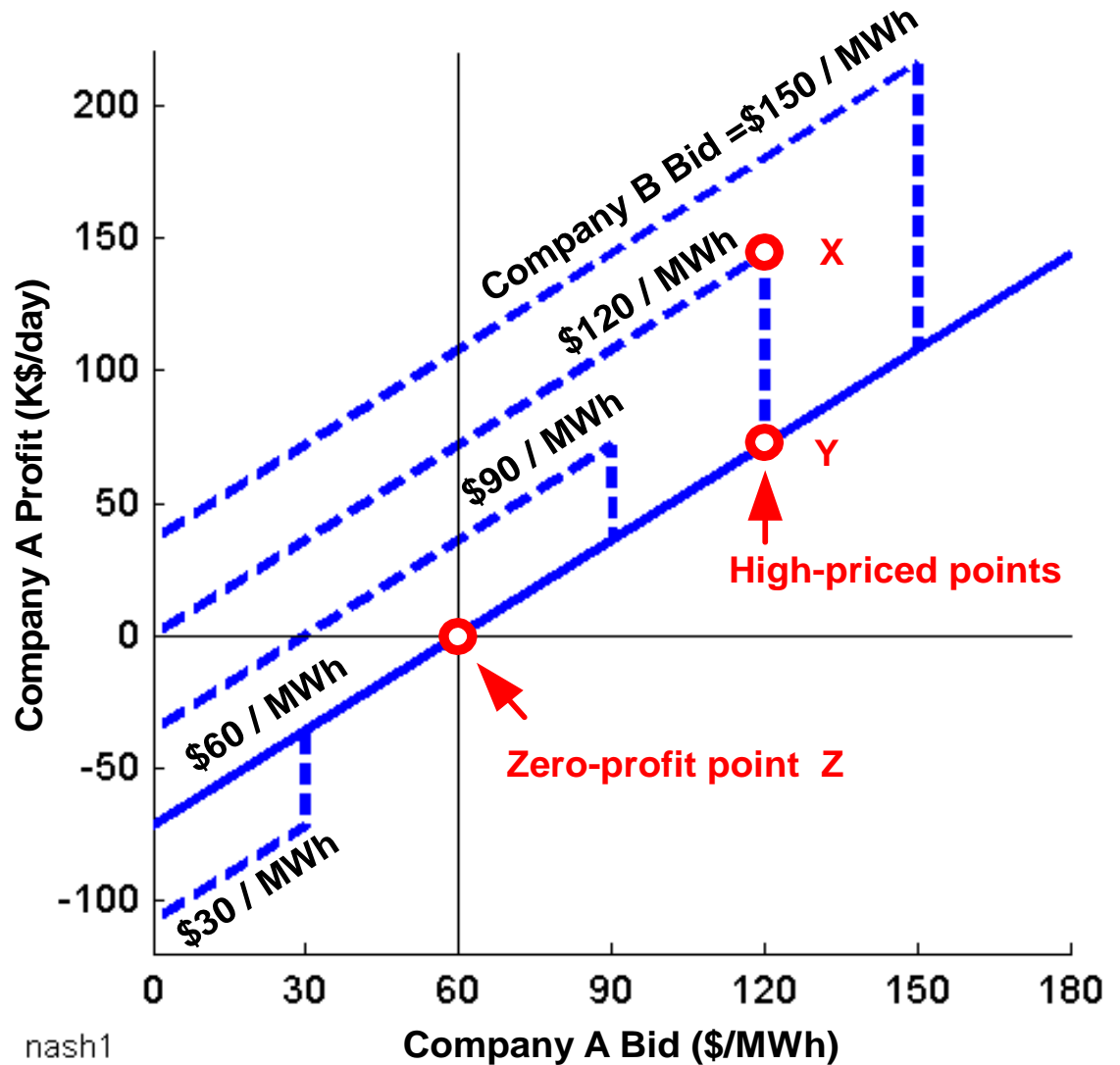

# Conditions for Nash Equilibrium

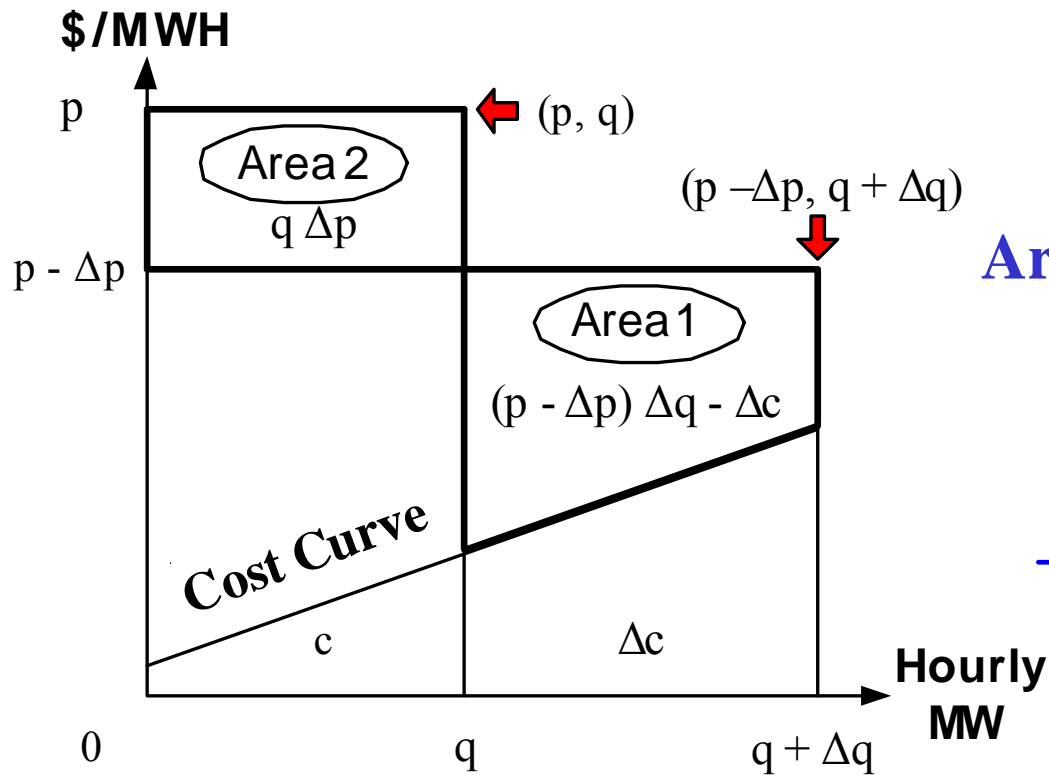

**Area 2 > Area 1 for all players**

$$\frac{\Delta p}{p} > \frac{\Delta q}{q} - \frac{\Delta p \Delta q + \Delta c}{p q}$$

**No more to sell at p  $\Delta q = 0$**

**Large company  $q \gg \Delta q$**

# Logical Strategy for Large Companies

Bid high and give market share to small companies

- No data available for proof

Other reasons for slow normalization of electricity price:

- Long-term gas contracts bound some to high cost
- Limit on bid prices during capacity deficiency based on past bids

# Evaluations

Price spikes might be wrong signals to send in Japan.

With price spikes like those in PJM in 1999, Japan would not be able to reduce the total fuel consumption through early retirement of inefficient units.

Uncertainty and instability are undesirable in Japan.

Without indigenous resources, Japan imports almost everything, and Japanese economy can be easily upset by shortages, market manipulation, unexpected and unplanned-for situations.

# Conclusions

Generation capacity growth in deregulated market is very difficult to predict:

- Market rules constantly change
- Bidders create innovative new strategies
- Developers and investors interpret price signals their own ways

U.S. type deregulation might not be good everywhere

- Uncertainty & instability affordable?
  - Search of market rules by trial & error
  - Boom-burst cycles
- Reasonable reserves & good mix of power plants obtainable?<sub>29</sub>